

Crio Line SB 2 Door Freezer Counter (R290)

ITEM # _____

MODEL # _____

NAME # _____

SIS # _____

AIA # _____



712415 (AJ2KBAA)

2-door freezer counter, -22-15°C, AISI 304 (R290)

Short Form Specification

Item No. _____

AISI 304 stainless steel panels, AISI 430 bottom panel, galvanized back panel. Worktop thickness 50mm. N. 2 full doors. Built-in refrigeration unit. Automatic defrost. Operating temperature: -15-22°C. R290 gas in refrigeration circuit. Supplied with 1 grid for each door compartment

Main Features

- Tropicalized unit (43°C ambient temperature).
- 0mm clearance installation space: tower configuration cooling unit guarantee performance with frontal ventilation only; this unique solution allows installation against the wall or side by side with other appliances, even on the cooling unit side to maximize the use of kitchen space.
- Frontal and easy access to all components in the cooling unit.
- Fully compliant HACCP digital control: when temperature exceeds critical limits, acoustic and visual alarms are activated. Up to two months of event are kept in memory.
- Self closing stainless steel doors (< 90°).
- Certified safety CE requirements.
- Prearranged to fit RS485 port to facilitate connection to a remote computer and integrated HACCP systems.
- Hot gas automatic evaporation of defrost water.
- Combination of doors and drawers to suit any configuration needed, with the possibility to change the configuration on site. Right cooling unit available on request.
- Anti-tilt runners accept GN 1/1 containers.
- Combination of doors and drawers to suit varying needs, with the possibility to change the configuration on site.
- Digital control panel.
- Forced air circulation for rapid cooling and an even temperature distribution.
- Refrigerated compartment designed to accept GN 1/1 containers.
- Preservation performances and temperature uniformity within the cell guaranteed at 5-HEAVY DUTY (40°C) working conditions according to EN16825:2016 test protocol.
- Small footprint to fit even in limited environments.
- Adjustable temperature range from -15 °C to -22 °C to suit meat, fish and dairy storage requirements.
- Digital control panel with temperature display.
- Adjustable temperature range from -15 °C to -20 °C to suit meat, fish and dairy storage requirements.
- Adjustable temperature range from -15°C to -22°C.
- Large digital white-digit display with humidity selection button (3 preset level), internal temperature display and setting, manual activation of defrost cycle and turbo frost cycle (to rapidly cool warm loads).
- Equipped with Airflow system: forced air circulation system for rapid cooling and even temperature distribution within the cell.
- Equipped with Optiflow forced air circulation system for rapid cooling and temperature distribution within the cell.
- Fully removable cooling unit to facilitate maintenance.
- Freezer compartment designed to accept GN1/1 containers.
- Mounted on stainless steel feet to give 150 mm (-5/+50 mm) clearance for ease of cleaning the floor.
- Connectivity ready for real time access to connected appliances from remote and data monitoring (requires optional accessory).
- Easy serviceability thanks to the intuitive control panel with remote access via app.
- Integrated RS485 port to facilitate connection to a remote computer and integrated HACCP systems.
- Internal structure with numerous charging positions available to host grids, ensuring higher net capacity and a

APPROVAL: _____

greater storage space.

- External bottom panel in stainless steel.
- External back panel in galvanized steel.

Construction

- Access to all components from the front.
- Built-in compressor to suit operating conditions.
- Developed and produced in ISO 9001 and ISO 14001 certified factory.
- Fault code display.
- Interior base with rounded corners, pressed from a single sheet.
- Rounded internal corners for ease of cleaning.
- Pre-arranged for drain-pipe.
- Built-in refrigeration unit.
- Internal structure with 15 charging positions (3 cm pitch) available to host GN 1/1 grids, ensuring higher net capacity and a greater storage space.
- Extractable cooling unit to facilitate maintenance.
- Ease of cleaning and high hygiene standards thanks to the rounded internal corners, the easily removable runners, grids and air conveyors.
- Mounted on Stainless steel adjustable legs to give 150 mm clearance for ease of cleaning.
- Internal and external doors, front, back and side panels in AISI 304 Stainless steel.
- IP21 protection index.
- Internal and external doors, front and side panels and removable worktop in AISI 304 Stainless steel.
- Worktop in AISI 304 Stainless steel with a 50 mm profile.
- Anti-drip profile on stainless steel worktop edge.
- 2 compartments with 2 doors.
- External back panel in galvanized steel.

Sustainability

- Removable triple-chamber balloon magnetic gasket to improve insulation and reduce energy consumption and ease of cleaning.
- CFC and HCFC free, highly ecological refrigerant type: R290 (ecological gas in foam: cyclopentane). Hydrocarbon refrigerant gas R290 for the lowest environmental impact (GWP=3), to reduce green house and ozone depletion effects.
- Fitted with 90 mm thickness of cyclopentane insulation for best insulating performance (thermal conductivity: 0,020 W/m²*K) and lowest environmental impact (GWP=3).
- Frost Watch Control starts automatically the defrosting process only when needed and ends once ice is melted, improving energy efficiency results.
- Hydrocarbon refrigerant gas R290 for the lowest environmental impact (GWP=3) - CFC and HCFC free.

Included Accessories

- 2 of Kit 1/1GN gray rilsan grid and 2 side runners for refrigerated counters PNC 881109

Optional Accessories

- 1/1GN gray rilsan grid for refrigerated counters PNC 881107
- 2 side runners for 1/1GN refrigerated counters PNC 881108
- Kit 1/1GN gray rilsan grid and 2 side runners for refrigerated counters PNC 881109
- 1/1GN plastic container, h65mm PNC 881110
- 1/1GN plastic container, h100mm PNC 881111
- 1/1GN plastic container, h150mm PNC 881112
- 2x1/2-drawer kit for refrigerated counters - h650mm PNC 881176
- Kit 4 wheels, h100mm (2 with brakes) for refrigerated counters PNC 881191
- Kit 4 wheels, h150mm (2 with brakes) for 2&3 compartment refrigerated counters PNC 881193
- Lock for refrigerator/freezer counters with 2 compartments - h650mm PNC 881245
- Kit 4 (45mm) spacers for wheels for refrigerator/freezer counters PNC 881277

Front

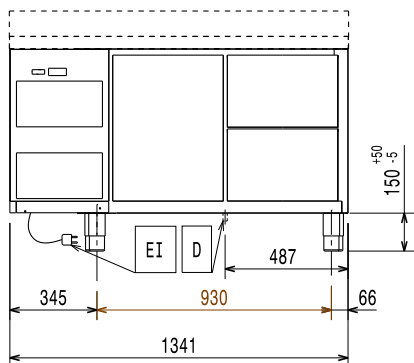

Side

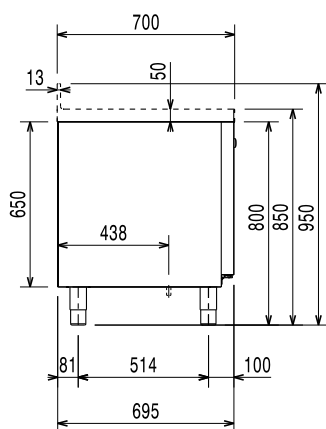

EI = Electrical inlet (power)

Top

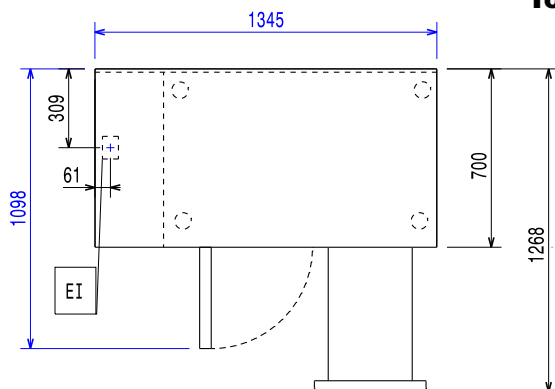

Electric

Supply voltage:	712415 (AJ2KBAA)	220-240 V/1 ph/50 Hz
Electrical power max.:		0.49 kW

Key Information:

Gross capacity:	
Net Volume:	160.4 lt
N° of doors:	
External dimensions, Width:	1345 mm
External dimensions, Depth:	700 mm
External dimensions, Depth with Doors Open:	1310 mm
External dimensions, Height:	850 mm
Internal Dimensions, Width:	798 mm
Internal Dimensions, Depth:	560 mm
Internal Dimensions, Height:	550 mm
Shipping volume:	1.08 m ³
Depth with doors open:	1310 mm
Height adjustment:	-5/50 mm

Built-in Compressor and Refrigeration Unit

Refrigeration Data

Control type:	Digital
Compressor power:	3/4 hp
Min/Max internal humidity:	
Operating temperature min.:	-15 °C
Operating temperature max.:	-22 °C
Operating mode:	Ventilated

Sustainability

Energy Class (EU Reg. 2015/1094):	C
Yearly and daily energy consumption (EU Reg. 2015/1094):	1600kWh/year - 4kWh/24h
Climate class (EU Reg. 2015/1094):	Heavy Duty (5)
Energy Efficiency Index-EEI (EU Reg. 2015/1094):	48,24
Refrigerant type:	R290
GWP Index:	3
Refrigeration power:	569 W
Refrigerant weight:	140 g

EU energy labelling from 1st July 2016

The European energy labelling scheme for professional refrigerators and freezers is based on requirements setting Minimum Energy Performance standards for commercial refrigeration cabinets sold within the EU. These requirements are designed to drive energy efficiency and environmentally friendly approach for professionals. The European energy labelling scheme will apply to all manufacturers and importers who sell and market products within the EU and it is mandatory across Europe. Important: all products which consume energy above the minimum level will not be able to be sold within the EU from 1 July 2016.

SI 2020 No. 1528.

Important: all products which consume energy above the minimum level will not be able to be sold within the EU from 1 July 2016.

